

7172 GY meskantafsluiter handwiel

APPLICATION

General use : Pulp production, water, water treatment, waste water, chemical industry (powdery or crystallizing products), wine-producing, pulverized products (cement work, pneumatic transport, stocking).

GENERAL CHARACTERISTICS

Function ON/OFF or regulation.
Wafer threaded mounting ISO PN10.
Unidirectional tightness, direction indication thanks to the arrow on the body.
Small retention zone: the gate is guided in the body and has little clearance.
Gland assembly: packing and O-ring (same material as seat joint) to assure the elasticity and decrease the operating torque.
Small head loss.
Possibility to regulate thick fluids the adaptation of a diaphragm ring .

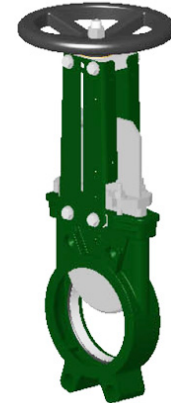

CONSTRUCTION

14**	1	Support ring	Stainless steel 316	DIN : X5CrNiMo18 10 ASTM : A 182 AIS 3 16 BS : 316 S16
13	1	Handwheel	Cast iron	DIN : GG 25 ASTM : A48 class 40B BS : 1452 Grade 250
12	2	Nut	Stainless steel	
11	1	Friction washer	Bronze	
10**	1	Gasket	Nitril	
9	1	O-ring	Nitril	
8	1	Packing gland	Ductile iron	
7	1	Nut	Bronze	
6	1	Nut support	Zinc steel	
5*	2	Support plate	Steel + epoxy	
4	1	Stem	Stainless steel	
3	1	Knife gate	X5CrNi 18-10	DIN : X5CrNi 18-10 ASTM : AISI 304 BS : 304 S15
2	2	Packing	PTFE	
1	1	Body	Ductile iron EN-GJS-500-7	DIN : GGG 50 ASTM : A536 65-70-50-05 BS : 1563 EN-JS1050
Pos.	Qty.	Description	Material	

* Pre-shaped parts up to DN 300.
** Missing parts on metal / metal tightness.

DIMENSIONS

DN		A	B	C	D	Ø V	H	Ø K	n	Ø M	Weight (kg)
mm	inch										
50	2"	40	105	124	94	200	291	125	4	4-M16	7,5
65	2 1/2"	40	115	139	94	200	318	145	4	4-M16	8,8
80	3"	50	124	154	94	200	342	160	8	4-M16	9,4
100	4"	50	140	174	94	200	383	180	8	4-M16	11,5
125	5"	50	150	189	100	250	420	210	8	4-M16	15,4
150	6"	60	175	220	101	250	471	240	8	4-M20	18,5
200	8"	60	205	275	124	310	577	295	8	4-M20	34,8
250	10"	70	250	326	126	310	677	350	12	8-M20	47,0
300	12"	70	300	380	128	310	777	400	12	8-M20	61,0
350	14"	96	339	438	290	500	939	460	16	10-M20	117,0
400	16"	100	392	494	290	500	1037	515	16	10-M24	151,0
450	18"	106	434	547	290	500	1125	565	20	14-M24	187,0
500	20"	110	487	613	290	500	1237	620	20	14-M24	205,0
600	24"	110	592	716	290	500	1432	725	20	14-M27	292,0

WORKING CONDITIONS

Maximum working pressure : DN 50-250 : 10 bar
DN 300-450 : 7 bar
DN 500-600 : 4 bar

Maximum temperature : -10°C / +80°C

Others materials on request (if marked)	Maximum temperature	
Metal / metal	T max : -10°C / +80°C.	<input type="checkbox"/>
White NBR	T max : -10°C / +80°C.	<input type="checkbox"/>
EPDM	T max : -10°C / +130°C.	<input type="checkbox"/>
Silicone	T max : -10°C / +170°C.	<input type="checkbox"/>
FPM (Type Viton®)	T max : -10°C / +170°C.	<input type="checkbox"/>
PTFE***	T max : +4°C / +170°C.	<input type="checkbox"/>
CSM (Type Hypalon®)	T max : +4°C / +80°C.	<input type="checkbox"/>

*** Minimum working pressure : 1 bar

STANDARDS

Manufacture according to the requirements of the Europeandirective 97/23/CE «Equipments under pressure» : modulate H.
On request : Product in accordance to european directive "Potentially explosive atmospheres" N° 94/9/EC : ATEX II 2 GD c and ATEX II 3 GD c.
Test procedures are established according to standard EN 12266-1, DIN 3230, BS 5154 and ISO 5208.
Connections according to standard EN 1092-2 and DIN 2501 : ISO PN10.

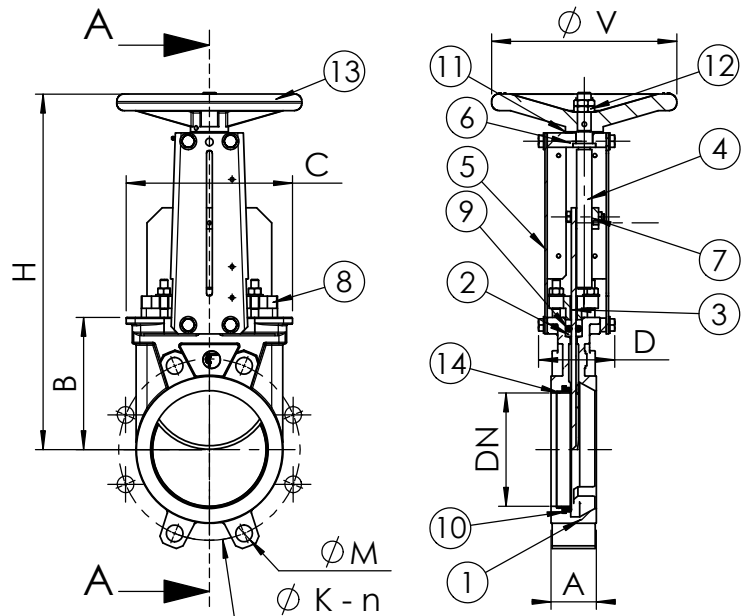

The photographs and technical art works are not contractual. The specifications of the presented products are open to modifications without previous advice.